

VISIONLINE

Process monitoring of machine tools



**DIGITIZE YOUR
MANUFACTURING**

Productlist

VisionLine 2.0 - Camera systems

<i>Article number</i>	<i>Designation</i>
R00000.50.00	VisionLine RWC 2.0 - external ball joint - 90° lens
R00000.51.00	VisionLine RWC 2.0 - external ball joint - 142° lens
R00000.53.00	VisionLine RWC 2.0 - internal ball joint - 90° lens
R00000.54.00	VisionLine RWC 2.0 - internal ball joint - 142° lens
R00000.70.00	VisionLine EAC 2.0 - external ball joint - 90° lens
R00000.71.00	VisionLine EAC 2.0 - external ball joint - 142° lens
R00000.73.00	VisionLine EAC 2.0 - internal ball joint - 90° lens
R00000.74.00	VisionLine EAC 2.0 - internal ball joint - 142° lens
R00000.80.00	VisionLine EC 2.0 - external ball joint - 90° lens
R00000.81.00	VisionLine EC 2.0 - external ball joint - 142° lens
R00000.83.00	VisionLine EC 2.0 - internal ball joint - 90° lens
R00000.84.00	VisionLine EC 2.0 - internal ball joint - 142° lens
R0000.23.02	Single magnetic holder for camera

Monitors

<i>Article number</i>	<i>Designation</i>
R04.31.00	Monitor 10,1" - metal housing, IP65 front side
R04.27.00	Monitor 15,6" - metal housing, IP65 front side
R04.04.00	Monitor 22"
R04.05.00	Monitor 24"
R04.41.00	Monitor 43"
R04.34.00	Monitor mount with ball joint

Network & Streaming

<i>Article number</i>	<i>Designation</i>
R004.14.00	Uyar Video Encoder
R004.08.00	NVR 8 channel, 2 TB
R004.09.00	NVR 8 channel, 4 TB
R004.11.00	NVR 16 channel, 8TB
R004.13.00	NVR 32 channel, 16TB
R004.15.03	HDMI-Extender

others

<i>Article number</i>	<i>Designation</i>
R004.14.00	HDMI Splitter (active)
R05.09.00	HD-Recorder incl. remote control

Visit our website to explore the full selection of accessories, connectors and cables. We've carefully crafted our product range to ensure you have all the options you need to make your process monitoring a reality.

What is the UYAR VISIONLINE?



Cooling lubricants are indispensable for machining processes in machine tools, but make it difficult for the machine operator to see the production process. Spinning windows are already trying to solve this problem, but they entail considerable restrictions with regard to the viewing area and the associated ergonomics. With the innovative camera system for process monitoring for wet and dry areas of machine tools, you increase your productivity, increase process reliability and improve the ergonomics of the operating personnel.

The UYAR VISIONLINE offers the right solution for all areas related to the production process in the machine tool. The system can be integrated into lathes, milling machines, grinding machines or robot cells. The main application is process monitoring in the operative manufacturing business. Our system is also the ideal solution for presenting machines, tools or processes at trade fairs or in showrooms. In order to make the video signal available for production planning, accessory devices offer the option of bringing the video stream into the network. It is also possible to record the video stream in order to analyze machine malfunctions or crashes afterwards.



Blind window in the manufacturing process



Installation of RWC 2.0 in 5-axis milling machine

What advantages does the UYAR VISIONLINE offer?



Always a clear view

UYAR camera systems create insights into your production processes. Whether heavily splashing cooling lubricants in machine tools or dry machining in robot cells, our product portfolio offers the right solution for every application.



Increased process reliability

Immediate intervention by the operator thanks to zero latency image transmission via HDMI. The operator no longer has to rely solely on his hearing and other technical assistance systems, which means more control over the machining process.



Modular system landscape

If you have already installed one of our camera systems, but need a recording function later or would you like to bring the video signal into the network. Our camera systems are designed in such a way that all accessories can be easily retrofitted.



Ergonomic work

The monitors can be freely positioned and mounted so that they can be swiveled and tilted. Ideal for changing operating personnel e.g. in multi-shift operation. Optimum field of view adjustment to the needs of the operating personnel.



Multiple display options

You can transmit several camera signals to one monitor or display one camera signal on different monitors using a signal splitter, this always offers the operator the best possible view of the production process.



Flexible installation options

With numerous options for quick installation in front of the housing wall or roof, we offer all options for an individually optimized camera setup. The camera systems can be installed in both new and used machines with minimal effort.



Recording

In order to increase the effectiveness of the manufacturing process, it is important to avoid disruptions. Using the recording function, cause analyzes can be carried out after a fault in order to continuously improve the production process and strive for fault-free operation.

Which products are part of the UYAR VISIONLINE?



The RWC 2.0 can be used for process monitoring in production areas with heavy spraying of cooling lubricants. A rotating special glass pane, which is located in front of the camera lens, is able to throw away all cooling liquids and chips due to the rotational movement.



The EAC 2.0 can be used for visual process monitoring of machining areas that are under the influence of low to medium splashing cooling lubricant emulsions. A special compressed air attachment creates a constant curtain of air in front of the camera lens, which repels cooling water and chips.



The EC 2.0 is the ideal solution for visual process monitoring in wet and dry rooms where no splashing cooling lubricants are used, such as in tool changing systems, robot cells, laser systems and loading systems. The slim design makes it possible to use it even in cramped workspaces.

	RWC 2.0	EAC 2.0	EC 2.0
Resolution	1080p (60, 30 fps)	1080p (60, 30 fps)	1080p (60, 30 fps)
Angle of view*	90° (optional 142°)	90° (optional 142°)	90° (optional 142°)
Connection options	HDMI	HDMI	HDMI
Cooling lubricants amounts	☹☹☹	☹☹	×
Oil	✓	×	×
Lighting	✓	×	×
Areas of application	lathes, milling machines, grinding machines, rolling mills	lathes, milling machines, woodworking machines	dry machining, tool changing systems, loading systems, laser systems, robot cells

Comparison table

* 90° lenses are installed as standard. On request, 142° lenses can be installed.



All camera systems can be expanded modularly, e.g. to bring the video stream into the network or to record it. Please refer to page 7 for more detailed information on the expansion options.

How can the camera systems be configured?

What types of lenses are available?

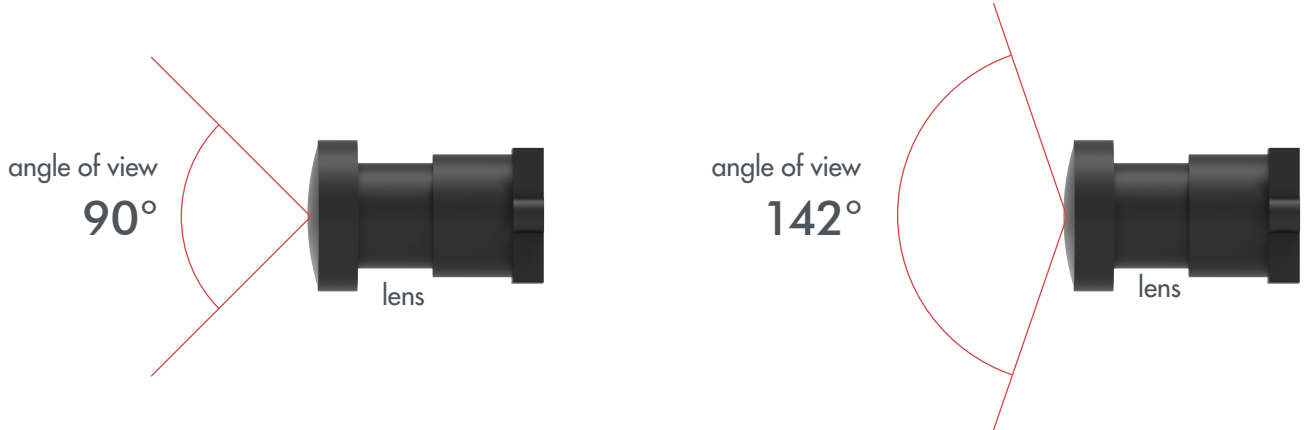

What are the types of mounting?



RWC 2.0 with internal ball joint

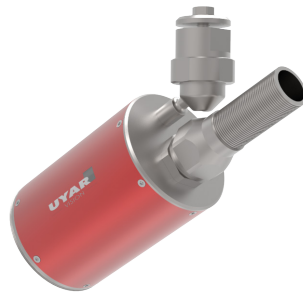

RWC 2.0 with external ball joint



RWC 2.0 with external ball joint & magnetic holder

What hose lengths are available for the external ball joint?

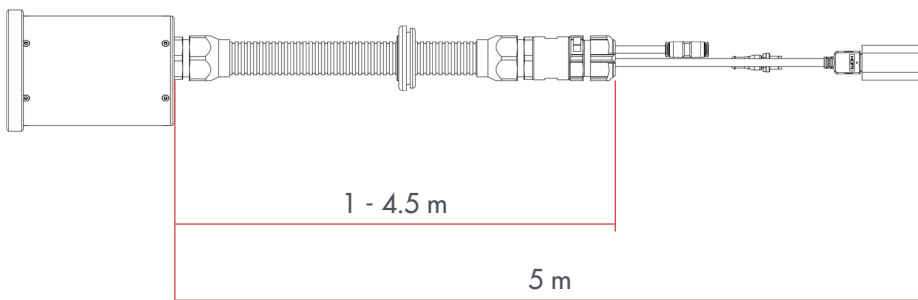

In the standard configuration, UYAR camera systems are delivered with 5 m connection cable and 1 m stainless steel protection hose. The stainless steel protection hose can be configured in 0.5 m increments from 1 m to 4.5 m on request.

How is the UYAR VISIONLINE installed?

To mount the camera with the external ball joint (5), an $\text{\O} 8.2$ mm hole must be drilled in the machine wall (3) in advance. The subsequent assembly is carried out using an O-ring (4), a washer (2) and a countersunk screw (1).

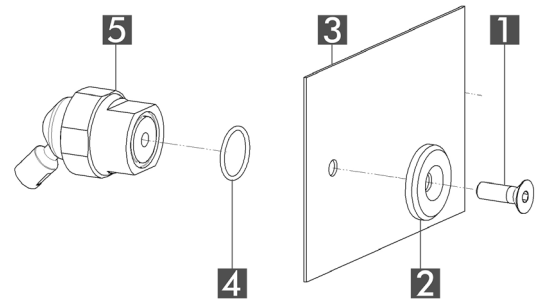

To route the hose package through the machine wall (1), a $\text{\O} 42$ mm hole must be punched into the machine wall.

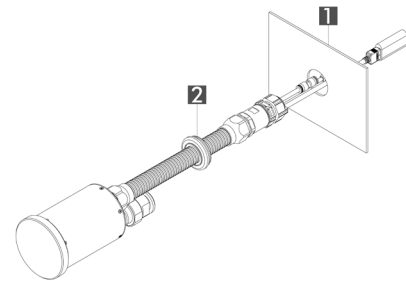

In order to continue to guarantee the tightness of the machine room, the assembly seal (2) must be inserted into the machine wall (1).

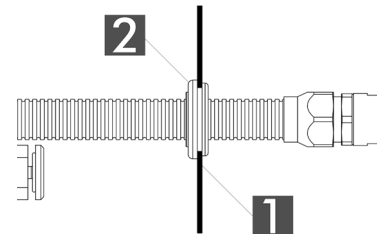

Finally, the three connecting cables will be connected. A power supply (1) of 24 V is required for this. The video signal is connected to a terminal device via the HDMI socket (2). In addition, a compressed air supply (3) using a PA6 hose is required for the RWC 2.0 and EAC 2.0.

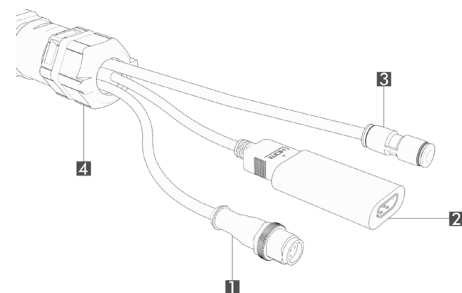

This representation is the "external ball joint" variant. This can be expanded with a magnetic holder if flexibility in positioning is desired. In addition, the portfolio offers an internal ball joint.

What accessories does the UYAR VISIONLINE offer?



IP Encoder

The IP encoder converts the HDMI signal into a network-capable RTSP stream, which can then be streamed using a video player on the PC.



Network Video Recorder (NVR)

When the IP encoder has generated a RTSP stream, the video signal can be routed to the NVR. 8, 16 or 32 video signals can be streamed on the browser, recorded and transferred to mobile devices using the associated app.



HDMI - Splitter

If you want to display the video stream on multiple monitors, the HDMI splitter offers the option of splitting the video signal. In this way, the operating personnel can monitor the process on several monitors.



HDMI Extender

If the video signal has to be transported over long distances, it is converted using an HDMI extender. Distances of up to 70m are easily possible. Since network cables are used for data transmission, drag chain capabilities are also given.



HDMI-Capture / Frame Grabber

With the HDMI capture, content can be viewed on a PC/laptop in live streaming. Simply connect via USB and start immediately.



Video-Recorder

With the help of the video recorder, video recordings can be made directly on the machine and saved on SD cards, USB sticks or external hard drives.



Streaming and recording in the network via IP encoder and NVR on a PC

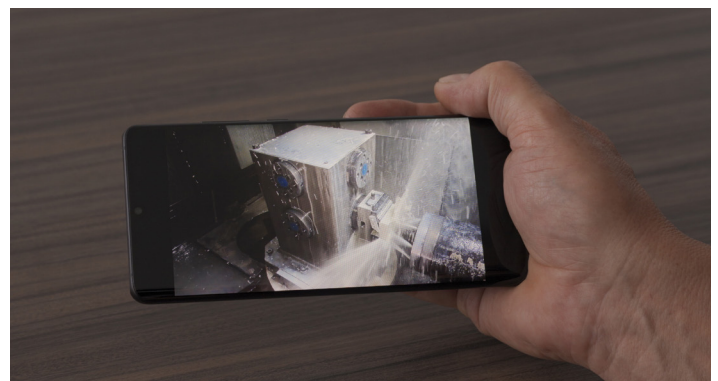

Streaming in-/outside the network via IP encoder and NVR on mobile devices

UYAR provides support throughout the entire process chain!

Run-in process

With our products, visual control for the machine operator during the run-in process becomes safer and effortless. Efficiency gains in the process result from the elimination of interruptions normally caused by the frequent opening of the machine door.

In addition, the continuous optical control leads to a significant reduction in collisions in the processing area. The effects are clear: lower scrap costs, fewer machine downtimes and as a result, significantly increased productivity.

Series process

The UYAR camera systems enable permanent monitoring of the tool and workpiece, which provides you with valuable information for the continuous improvement of your production process.

In addition, our products offer immense advantages in the organization of production personnel. Through optical control of the machining process, UYAR camera systems are an enabler for multi-machine operation.

Production digitization

Credentials



Application example: Horizontal machining center



The application example shows a horizontal 3-axis machining center. The problem for the machine operator with this type of machine is that there is no view of the rear side during the production process. For this reason, two RWC cameras are positioned in the processing room. In addition, an EAC in the tool magazine and an EC in the pallet changer offer the possibility of monitoring the entire machine. Thanks to the 43" monitor with split-screen function, up to 4 video streams can be played simultaneously.

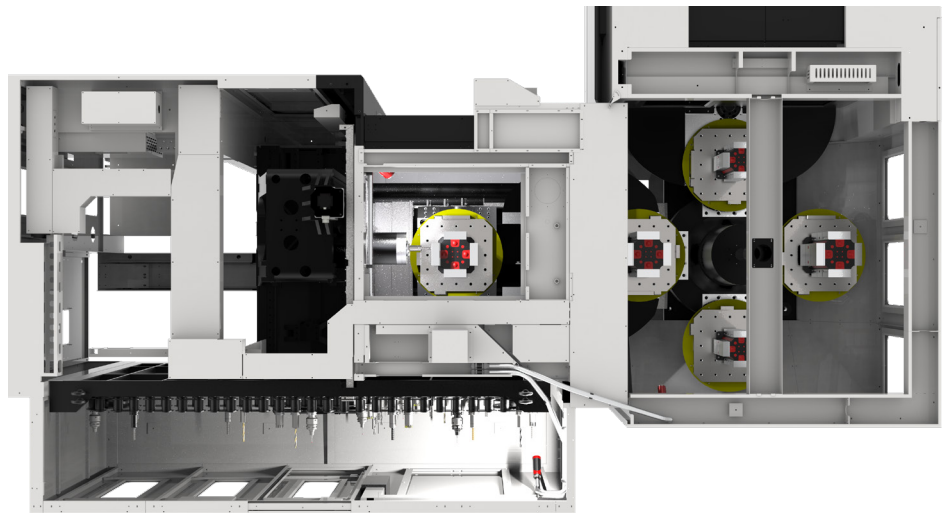

Top view of horizontal BAZ



Machine room with two RWC 2.0



Tool changing magazine with EAC 2.0

[LINK TO VIDEO](#)



Application example: Showroom / Fair

The product presentation of machine tools as well as milling and turning tools at trade fairs and in showrooms lives from the realistic machining process under chip and cooling lubricant. UYAR camera systems support you in moving your machine tools and tools even more into the center of the action and thus also offer insights into the manufacturing process to a large professional audience.

The advantage of the RWC 2.0 and EAC 2.0 in this application is the free positioning of the cameras in the processing area, which offers completely new perspectives on the machining process.



RWC in a machining center
with 55" monitor

Application example: Lathe

In lathes in particular, cooling lubricants are usually thrown onto the machine disk at high pressure due to the rotary motion. Rotating viewing windows are not a solution in these applications, as they would block the machine door, and they are also exposed to the entire cooling lubricant pressure. The advantage of the RWC 2.0 and EAC 2.0 in this application is the free positioning of the machine room camera, which offers completely new perspectives on the machining process.

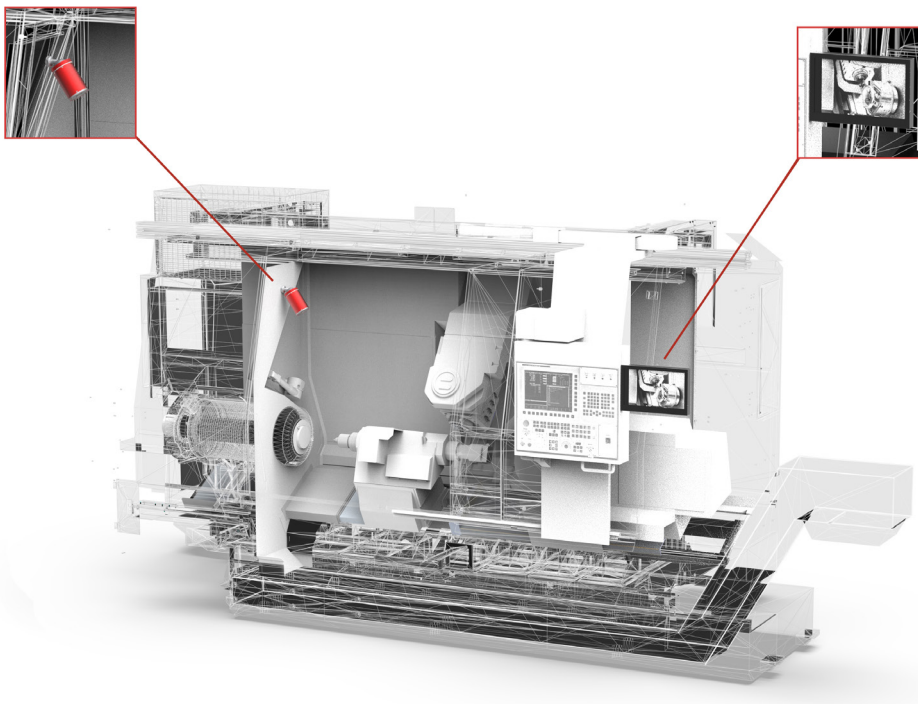

More information:

✉ sales@uyarvision.com

🌐 www.uyarvision.com

UYAR GmbH & Co. KG
Carl-Bosch-Straße 6
DE - 33790 Halle (Westfalen)

As at:
2nd edition, 2023

Copyright
by UYAR GmbH & Co. KG
Carl-Bosch-Straße 6 · 33790 Halle (Westfalen)

All rights reserved, including translation rights. No part of this description may be duplicated, reproduced, stored in an information system or processed or transferred in any other form without prior express written permission of UYAR GmbH & Co. KG.

This document has been prepared with care. UYAR GmbH & Co. KG cannot accept any liability for any errors in this document or for the consequences of such errors. Equally, no liability can be accepted for direct or consequential damages resulting from improper use of the products.

Subject to modifications.

The respective current version of this document is available on UYAR's website: www.uyarvision.com